



# 8xMPS-A

8 Channels miniature differential and absolute pressure sensor for CAN bus

SN: P#####

Texense sensors are designed for data logging. Should the users want to include this sensor in a closed loop system, they must undertake total responsibility from doing so.

Differential pressure		
Range	±50 to ±600	mBar
Sensitive Element	Piezo resistive cells	
Proof Pressure	1.7	Bar
Resolution	Range ≤ ±250 mBar	0.01 mBar/bit
	Range > ±250 mBar	0.1 mBar/bit
Max offset error (from 5°C to 105°C)	± 0.1	mBar
Max hysteresis and non-repeatability error (from 5°C to 105°C)	± 0.15	mBar
Max non-linearity error (from 5°C to 105°C)	± 0.1	% FS
Noise	At 10Hz	3 μBar
	At 200Hz	10 μBar
Sampling frequency	800	Hz
Analog filter cut off frequency	200	Hz
Output frequency	1Hz to 200Hz or on trigger	
Absolute pressure		
Range	600 to 1200	mBar
Proof Pressure	2.5	Bar
Resolution	10	μBar/bit
Accuracy (from 5°C to 105°C)	± 1	mBar
Sampling frequency	800	Hz
Analog filter cut off frequency	200	Hz
Output frequency	1Hz to 200Hz or on trigger	
Internal temperature		
Range	-20 to 120	°C
Sampling Frequency	40	Hz
Output frequency	5	Hz
Common		
CAN type	2.0A or 2.0B	-
CAN baudrate	250 to 1000	kbps
Supply Voltage	6 to 30	V
Supply Current (at 12V)	20	mA
Calibrator	MENSOR CPC4000	
Dimensions	40.3 x 32.4 x 9.5	mm
Material	Aluminum	
Weight (without cable)	23	g
Protection	IP64	
Vibration test	20Gpp 5'	
Shock	500	G
Operating Temp	+5 to +125	°C
Storage Temp	-40 to +125	°C

Date		Operator	
Customer			
Order			
Product Ref	8xMPS-A-M###-P###		
SW version	V#.#		

Sensor readings			
Channel	at ... mbar	at ... mbar	at ... mbar
1			
2			
3			
4			
5			
6			
7			
8			
Absolute	at ... mbar		at ... mbar

Software setup	
CAN type	2.0A
CAN output	Standard
Baudrate	1Mbps
Frequency	10Hz
Rx trig ID	0x7F0
Tx1 ID	0x3F0
Tx2 ID	0x3F4
Tx3 ID	0x3F8
Tx4 ID	0x3FC
Sensor ID	0
Autozero	Enabled
Hardware setup	
CAN termination resistor	Not connected

Cable		
5x26 AWG FEP tinned copper braided cable 250V 200°C		
Length: 1000mm		
Tubing: 50mm Connector: on request		
Color	Function	Pin
Red	Supply input	-
Black	0V	-
White	CAN Low	-
Green	CAN High	-
Yellow	Do not connect and isolate	-

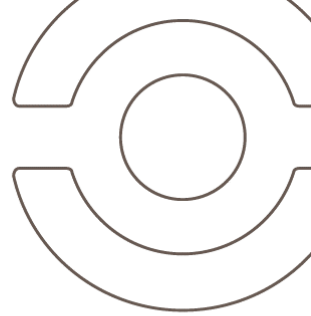

## Mechanical drawing

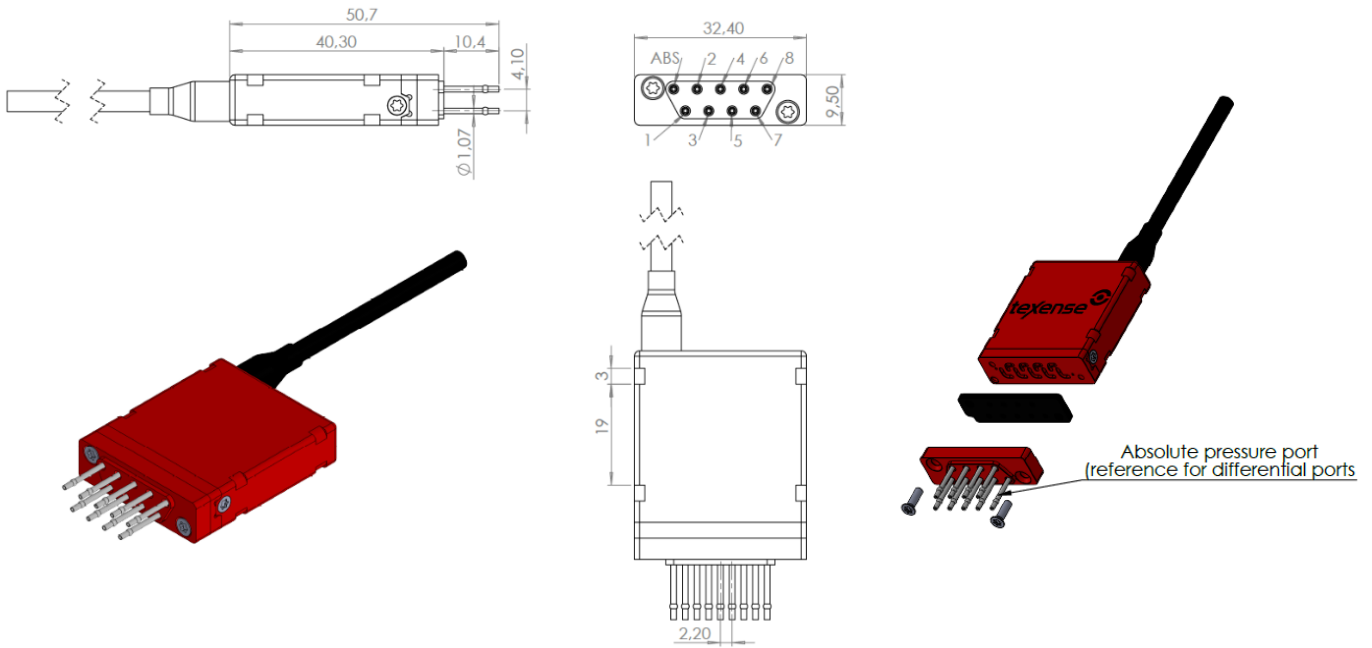

## Pressure ports description

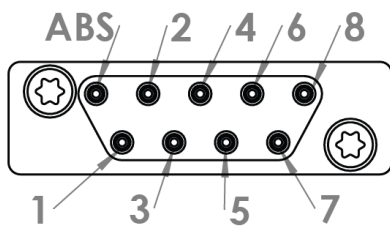
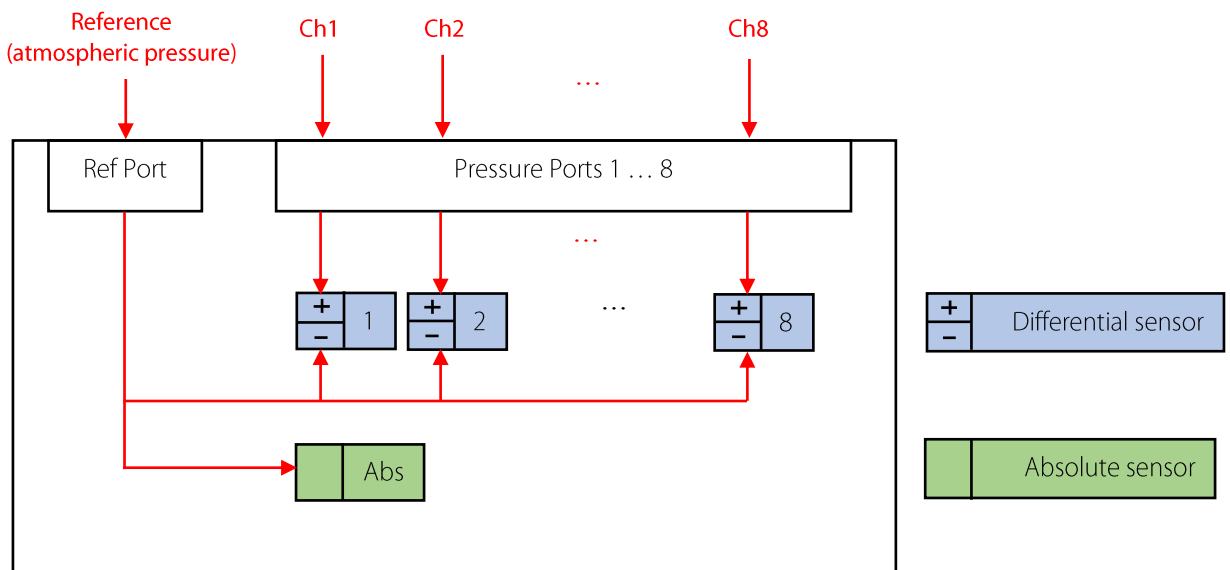

This sensor withstands high humidity. Avoid water entering in the tube as well as condensation, it may block the pressure. Do not blow into the tubes with the mouth or a compressed air line.

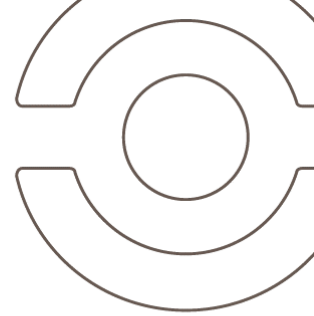

## CAN data output: Standard mode

Frequency: 1 to 200Hz

Tx1 ID (Default: 0x3F0)	Byte 0 MSB	Byte 1 LSB	Byte 2 MSB	Byte 3 LSB	Byte 4 MSB	Byte 5 LSB	Byte 6 MSB	Byte 7 LSB
	Differential pressure 1		Differential pressure 2		Differential pressure 3		Differential pressure 4	
	Signed integer 16 bit		Signed integer 16 bit		Signed integer 16 bit		Signed integer 16 bit	

Tx2 ID (Default: 0x3F4)	Byte 0 MSB	Byte 1 LSB	Byte 2 MSB	Byte 3 LSB	Byte 4 MSB	Byte 5 LSB	Byte 6 MSB	Byte 7 LSB
	Differential pressure 5		Differential pressure 6		Differential pressure 7		Differential pressure 8	
	Signed integer 16 bit		Signed integer 16 bit		Signed integer 16 bit		Signed integer 16 bit	

Tx3 ID (Default: 0x3F8)	Byte 0 MSB	Byte 1 LSB
	Absolute pressure	
	Unsigned integer 16 bit 600mbar + 10µBar/bit	

Internal temperature (5Hz output rate):

Tx4 ID (Default: 0x3FC)	Byte 0 MSB	Byte 1 LSB	Byte 2 MSB	Byte 3 LSB
	Internal temperature		Not used	
	Signed integer 16bits 0.1°C/bit			

## CAN data output: Multiplexed mode

Frequency: 1 to 200Hz

Tx1 ID (Default: 0x3F0)	Byte 0	Byte 1	Byte 2 MSB	Byte 3 LSB	Byte 4 MSB	Byte 5 LSB	Byte 6 MSB	Byte 7 LSB
	Sensor ID	Multiplexed Msg ID = 0	Differential pressure 1		Differential pressure 2		Differential pressure 3	
			Signed integer 16 bit		Signed integer 16 bit		Signed integer 16 bit	

Tx1 ID (Default: 0x3F0)	Byte 0	Byte 1	Byte 2 MSB	Byte 3 LSB	Byte 4 MSB	Byte 5 LSB	Byte 6 MSB	Byte 7 LSB
	Sensor ID	Multiplexed Msg ID = 1	Differential pressure 4		Differential pressure 5		Differential pressure 6	
			Signed integer 16 bit		Signed integer 16 bit		Signed integer 16 bit	

Tx1 ID (Default: 0x3F0)	Byte 0	Byte 1	Byte 2 MSB	Byte 3 LSB	Byte 4 MSB	Byte 5 LSB	Byte 6 MSB	Byte 7 LSB
	Sensor ID	Multiplexed Msg ID = 2	Differential pressure 7		Differential pressure 8		Absolute pressure	
			Signed integer 16 bit		Signed integer 16 bit		Unsigned integer 16 bit 600mbar + 10µbar/bit	

Internal temperature (5Hz output rate):

Tx4 ID (Default: 0x3FC)	Byte 0	Byte 1	Byte 2 MSB	Byte 3 LSB
	Sensor ID	Multiplexed Msg ID = 0	Internal Temp. (°C)	
			Signed integer 16 bit 0.1°C/bit	

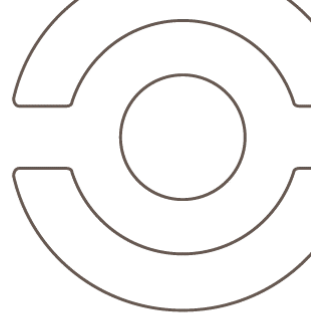

## CAN data input

Trig frame on CAN request mode (max 200Hz)

Rx ID (Default: 0x7F0)	Byte 0	Byte 1	Byte 2	Byte 3	Byte 4	Byte 5	Byte 6	Byte 7
	Sensor ID	Multiplexed Msg ID	-	-	-	-	-	-
	ID or 0xFF (all sensors)	0, 1, 2 or 0xFF (all Msg)						

Auto-Zero command for differentials pressures

Command input frame

0x7F1	Byte 0	Byte 1	Byte 2	Byte 3	Byte 4	Byte 5	Byte 6	Byte 7
	0xFF	-	-	-	-	-	0x00 or 0x01	0x01

0x00: volatile autozero  
 0x01: non-volatile autozero

Acknowledge output frame

0x7F3	Byte 0	Byte 1	Byte 2	Byte 3	Byte 4	Byte 5	Byte 6	Byte 7
	0xFF	Serial number				0x00	0x00	0x01
Unsigned integer 32 bit								

This command can be used to re-zero all channels. This mechanism can be enabled or disabled (please refer to “Enable Auto-Zero command” of the CAN parameters tab). Each time the sensor will receive one of the above CAN frames, the autozero function will be launched (except during first second after power-on). When autozero function is launched, a “customer offset” is set up and added for each channel on top of factory calibration.

**If Byte 6 value is 0x00:**

Those “Customer offsets” will be stored in volatile memory. Therefore, they will be lost when switching OFF the sensor and they will be initialized to 0 when switching ON the sensor.

**If Byte 6 value is 0x01:**

Those “Customer offsets” will be stored in non-volatile memory. Therefore, they will be saved in memory when switching OFF the sensor.

Offset adjustment command for absolute pressure

Command input frame

0x7F1	Byte 0	Byte 1	Byte 2	Byte 3	Byte 4	Byte 5	Byte 6	Byte 7
	0xFF	-	MSB	LSB	-	-	-	0x02
Desired absolute pressure								
Unsigned int 16 bit								
600mbar + 10µbar/bit								

Acknowledge output frame

0x7F3	Byte 0	Byte 1	Byte 2	Byte 3	Byte 4	Byte 5	Byte 6	Byte 7
	0xFF	Serial number				0x00	0x00	0x02
Unsigned integer 32 bit								

This command can be used to adjust the offset on absolute pressure channels. This mechanism can be enabled or disabled (please refer to “Enable Auto-Zero command” of the CAN parameters tab). Each time the sensor will receive the above CAN frame, the offset adjustment function will be launched (except during first second after power-on). When offset adjustment function is launched, a “customer offset” is set up and added on top of factory calibration. This “Customer offset” will be stored in non-volatile memory. Therefore, they will be kept in memory when switching OFF the sensor.

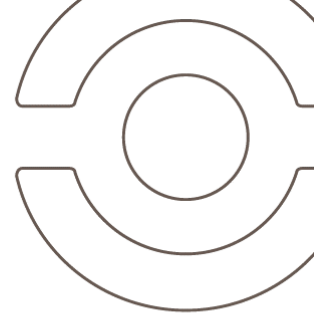

## CAN parameters

Must be setup according to Texense CAN protocol, or by using the tWist\* software (texense Windows software tool) with the tSIB (texense Smart Interface Box).

Address	Parameter	Raw values	Values	Comments	
0x00	CAN type	0x00	CAN 2.0A	Default	
		0x01	CAN 2.0B		
0x01	Baudrate	0x00	1Mbps	Default	
		0x01	500 Kbps		
		0x02	250 Kbps		
0x02	Emission frequency	0x00	Rx frame trigger mode	Fast response (max 320µs)	
		0x01	1 Hz		
		0x02	5 Hz	Default	
		0x03	10 Hz		
		0x04	50 Hz		
		0x05	100 Hz		
		0x06	200 Hz		
0x03	Rx Trig frame ID	if CAN2.0A: 0x1 to 0x7F0		MSB	Default 0x07F0
0x04		if CAN2.0B: 0x1 to 0xFFFF (except 0x7F1 to 0x7F3)		LSB	
0x05	Tx1 frame ID	if CAN2.0A: 0x1 to 0x7F0		MSB	Default 0x03F0
0x06		if CAN2.0B: 0x1 to 0xFFFF (except 0x7F1 to 0x7F3)		LSB	
0x07	If Standard CAN: Tx2 frame ID	if CAN2.0A: 0x1 to 0x7F0		MSB	Default 0x3F4
0x08		if CAN2.0B: 0x1 to 0xFFFF (except 0x7F1 to 0x7F3)		LSB	
0x09	If Standard CAN: Tx3 frame ID	if CAN2.0A: 0x1 to 0x7F0		MSB	Default 0x3F8
0x0A		if CAN2.0B: 0x1 to 0xFFFF (except 0x7F1 to 0x7F3)		LSB	
0x0B	Tx4 frame ID	if CAN2.0A: 0x1 to 0x7F0		MSB	Default 0x3FC
0x0C		if CAN2.0B: 0x1 to 0xFFFF (except 0x7F1 to 0x7F3)		LSB	

### Sensor parameters:

0x0D	Enable Auto-zero	0x00	Disabled	Default
		0x01	Enabled	
0x0E	Data format	0x00	Standard (3 frames)	Default
		0x01	Multiplexed (4 frames)	
0x0F	Sensor ID	If standard mode: Unused If multiplexed mode: From 0x00 to 0x0E		Default 0x00

For complete information, contact us at [info@texense.com](mailto:info@texense.com)

## Ordering information

### Ordering ref:

#### 8xMPS-A-Range

**M50-P50:** -50...50mbar  
**M70-P70:** -70...70mbar  
**M150-P150:** -150...150mbar  
**M250-P250:** -250...250mbar  
**M400-P400:** -400...400mbar  
**M600-P600:** -600...600mbar  
**M350-P70:** -350...70mbar

ex: 8xMPS-A-M250-P250