



A-CAN-DG-V4-4B

8 channels analog to CAN converter for voltage and RTD

SN: D#####

Texense sensors are designed for data logging. Should the users want to include this sensor in a closed loop system, they must undertake total responsibility from doing so.

ANA inputs		
Range	0 to 5.5	V
Accuracy	±1.5	mV
Resolution	0.1	mV
Sampling frequency	250	Hz
Analog filter cut-off frequency	125	Hz
Input impedance	10	kΩ
RTD measurement		
Range	100Ω to 1MΩ	Ω
Accuracy (in the range 800 Ω to 2500 Ω)	±1	Ω
Resolution	0.1	Ω
RTD Temperature calculation		
RTD model	Pt 1000	
Range	-125 to +125	°C
Uncertainty due to resistance measure error	±0.25	°C
Calculation uncertainty	±0.05	°C
Temperature uncertainty (with perfect RTD and 0Ω wires)	±0.30	°C
Internal temperature measurement		
Range	-40 to +125	°C
Uncertainty	±0.25	°C
CAN features		
CAN bus type	2.0 A or B	
Termination resistor	Software switchable 120Ω	
CAN baudrate	125k to 1M	bps
Output Frequency	ANA	1Hz to 250Hz, or on request
	RTD	10Hz
Electrical features		
Input supply voltage	6V to 30 V (see §Supply stage)	
Input supply current at 12V	≤ 30 mA internal ≤ 400mA with max load	
Output supply voltage	5V, 8.5V, 12V or Direct	
Max output supply current	45 mA per connector	

Date		Operator	
Customer			
Order			
Product Ref	A-CAN-DG-V4-4B-###		
SW version	V#.##		

Channel	Sensor readings			
	ANA input		RTD	
	@500mV	@4500mV	@-90.0°C	@90.0°C
#1	...mV	...mV	... °C	... °C
#2	...mV	...mV	... °C	... °C
#3	...mV	...mV	... °C	... °C
#4	...mV	...mV	... °C	... °C
#5	...mV	...mV	... °C	... °C
#6	...mV	...mV	... °C	... °C
#7	...mV	...mV	... °C	... °C
#8	...mV	...mV	... °C	... °C

CAN Data parameters			
CAN type	2.0A	2.0B	-
Baudrate	1M		bps
Frequency	10		Hz
Rx trig frame ID	0x7F0		Hex
Tx01 frame ID	0x3F0		Hex
Tx02 frame ID	0x3F4		Hex
Tx03 frame ID	0x3F8		Hex
Tx04 frame ID	0x3FC		Hex
Tx05 frame ID	0x400		Hex
CAN 120 Ω termination	<input type="checkbox"/> yes	<input checked="" type="checkbox"/> no	-

Mechanical features		
Dimension	23 x 26 x 85	mm
Material	Aluminium	
Weight	60	g
Environment		
Protection	IP65	
Vibration test	20Gpp5'	
Shock	500	G
Operating Temp	-40 to +125	°C
Storage Temp	-40 to +125	°C

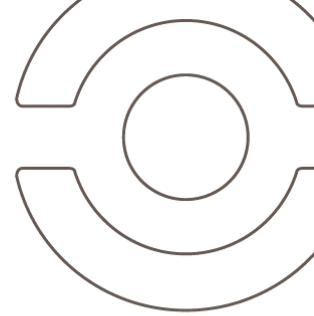

Pinout

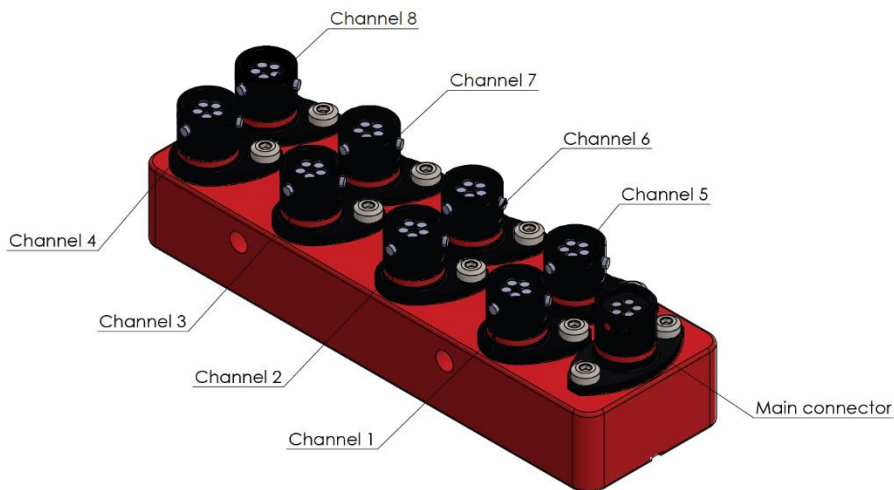

8x Channel connectors (#1 to #8)	
Connector ref: 8STA0-0205SN Mating connector ref: 8STA6-0205PN	
Pin	Function
1	Supply output
2	0V
3	ANA input
4	RTD +
5	RTD -

Main connector	
Connector ref: 8STA0-0205PN Mating connector ref: 8STA6-0205PN	
Pin	Function
1	Supply
2	0V
3	CAN Low
4	CAN High
5	Reserved (do not connect)

Mechanical drawing

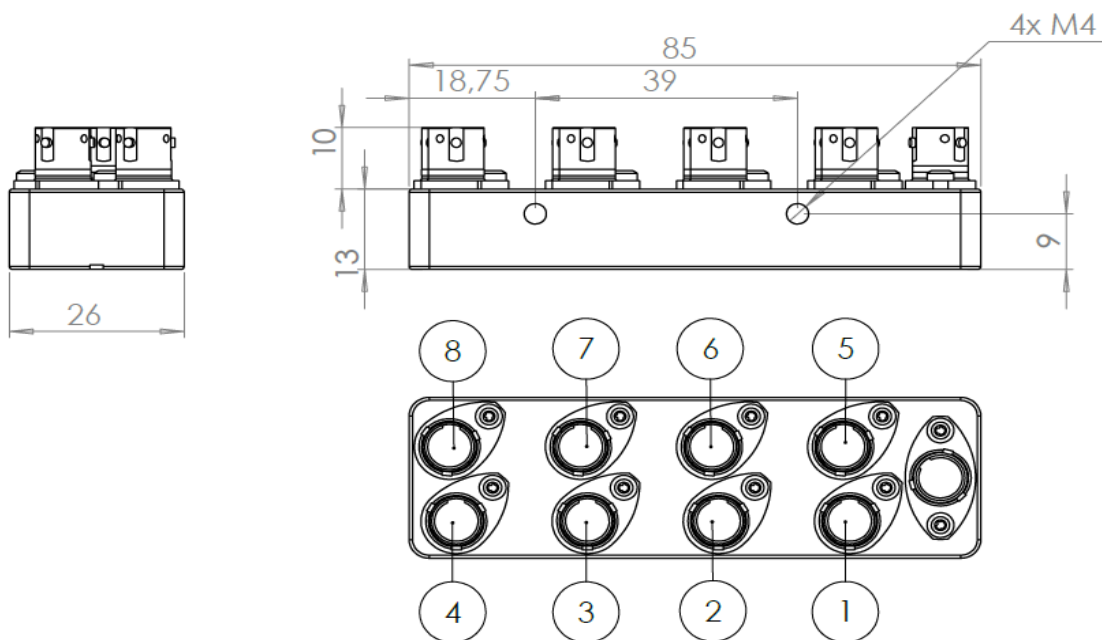

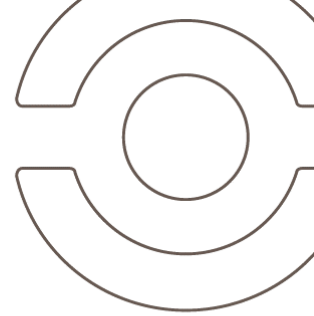

Wiring

For each channel connector:

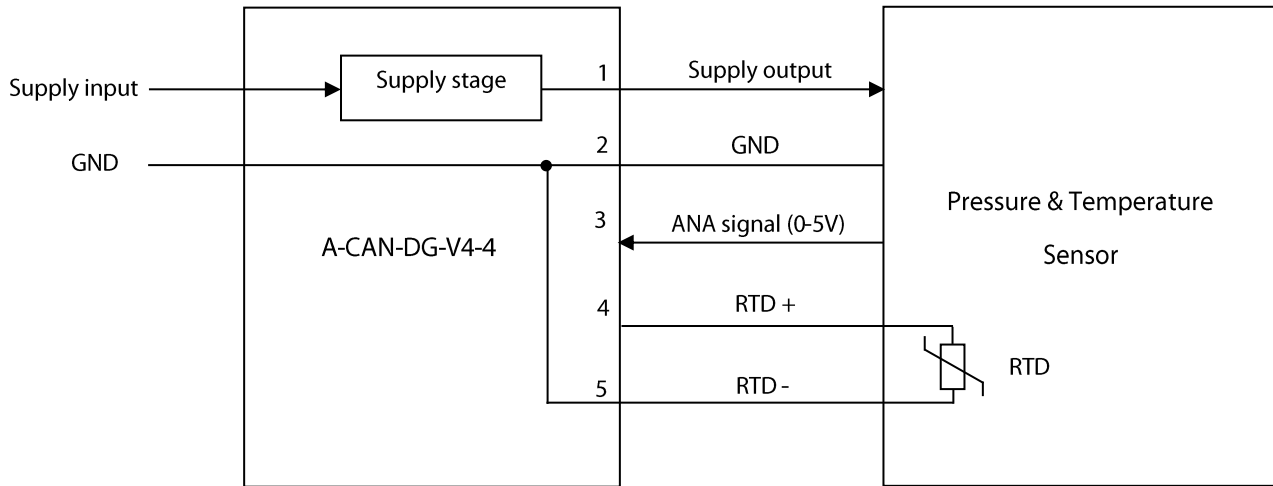

Note:

- Sensors have to be compatible with supply voltage and supply current (see \$Supply stage).
- All signals must be isolated from any other conductive part with at least 100MΩ under 50V.

Supply stage

Multiple supply stage configurations are available when ordering:

Ordering code	Output voltage	Input voltage range	Output current
5V	Regulated 5V	7V to 30V	30mA per channel
8.5V	Regulated 8.5V	10.5V to 30V	
12V	Regulated 12V	14V to 30V	
Direct	= Input supply voltage (not regulated)	6V to 30V	45mA per channel

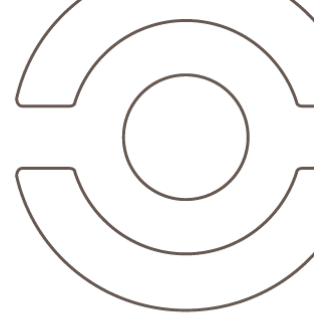

CAN data

Data output

TX Frame #01 (1 to 250Hz output rate)

ID	Byte 0	Byte 1	Byte 2	Byte 3	Byte 4	Byte 5	Byte 6	Byte 7
0x03F0 (default)	MSB	LSB	MSB	LSB	MSB	LSB	MSB	LSB
	Unsigned integer 16bits		Unsigned integer 16bits		Unsigned integer 16bits		Unsigned integer 16bits	
	Channel 1 voltage		Channel 2 voltage		Channel 3 voltage		Channel 4 voltage	
	0.1mV/bit		0.1mV/bit		0.1mV/bit		0.1mV/bit	

TX Frame #02 (1 to 250Hz output rate)

ID	Byte 0	Byte 1	Byte 2	Byte 3	Byte 4	Byte 5	Byte 6	Byte 7
0x03F4 (default)	MSB	LSB	MSB	LSB	MSB	LSB	MSB	LSB
	Unsigned integer 16bits		Unsigned integer 16bits		Unsigned integer 16bits		Unsigned integer 16bits	
	Channel 5 voltage		Channel 6 voltage		Channel 7 voltage		Channel 8 voltage	
	0.1mV/bit		0.1mV/bit		0.1mV/bit		0.1mV/bit	

TX Frame #03 (10Hz output rate)

ID	Byte 0	Byte 1	Byte 2	Byte 3	Byte 4	Byte 5	Byte 6	Byte 7
0x03F8 (default)	MSB	LSB	MSB	LSB	MSB	LSB	MSB	LSB
	Signed integer 16bits		Signed integer 16bits		Signed integer 16bits		Signed integer 16bits	
	Channel 1 RTD temp.		Channel 2 RTD temp.		Channel 3 RTD temp.		Channel 4 RTD temp.	
	0.1°C/bit		0.1°C/bit		0.1°C/bit		0.1°C/bit	

TX Frame #04 (10Hz output rate)

ID	Byte 0	Byte 1	Byte 2	Byte 3	Byte 4	Byte 5	Byte 6	Byte 7
0x03FC (default)	MSB	LSB	MSB	LSB	MSB	LSB	MSB	LSB
	Signed integer 16bits		Signed integer 16bits		Signed integer 16bits		Signed integer 16bits	
	Channel 5 RTD temp.		Channel 6 RTD temp.		Channel 7 RTD temp.		Channel 8 RTD temp.	
	0.1°C/bit		0.1°C/bit		0.1°C/bit		0.1°C/bit	

TX Frame #05 (10Hz output rate)

ID	Byte 0	Byte 1
0x0400 (default)	MSB	LSB
	Signed integer 16bits	
	Internal temperature	
	0.1°C/bit	

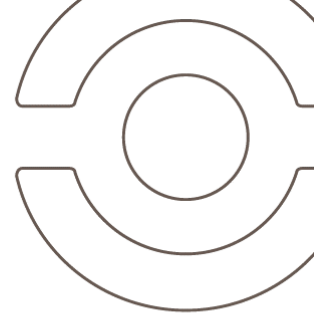

Changing parameters

Must be setup according to Texense CAN protocol, or by using the tWist[®] software (texense Windows software tool) with the tSIB (texense Smart Interface Box).

Address	Parameter	Raw values	Values	Comments	
0x00	CAN type A or B (11 or 29bits ID)	0x00	CAN2.0 A (standard)	default	
		0x10	CAN2.0 B (extended)		
0x01	CAN baudrate	0x00	1Mbps	default	
		0x01	500 Kbps		
		0x02	250 Kbps		
		0x03	125 Kbps		
0x02	CAN output frequency	0x00	Rx frame trig	Request mode - 20Hz max.	
		0x01	1 Hz		
		0x02	5 Hz		
		0x03	10 Hz	default	
		0x04	50 Hz		
		0x05	125 Hz		
		0x06	250 Hz		
0x03	Rx trig frame ID	if CAN2.0A: 0 to 0x7F0		MSB	Default 0x07F0
0x04		if CAN2.0B: 0 to 0xFFFF (except 0x7F1 and 0x7F3)		LSB	
0x05	Tx01 frame ID	if CAN2.0A: 0 to 0x7F0		MSB	Default 0x03F0
0x06		if CAN2.0B: 0 to 0xFFFF (except 0x7F1 and 0x7F3)		LSB	
0x07	Tx02 frame ID	if CAN2.0A: 0 to 0x7F0		MSB	Default 0x03F4
0x08		if CAN2.0B: 0 to 0xFFFF (except 0x7F1 and 0x7F3)		LSB	
0x09	Tx03 frame ID	if CAN2.0A: 0 to 0x7F0		MSB	Default 0x03F8
0x0A		if CAN2.0B: 0 to 0xFFFF (except 0x7F1 and 0x7F3)		LSB	
0x0B	Tx04 frame ID	if CAN2.0A: 0 to 0x7F0		MSB	Default 0x03FC
0x0C		if CAN2.0B: 0 to 0xFFFF (except 0x7F1 and 0x7F3)		LSB	
0x0D	Tx05 frame ID	if CAN2.0A: 0 to 0x7F0		MSB	Default 0x0400
0x0E		if CAN2.0B: 0 to 0xFFFF (except 0x7F1 and 0x7F3)		LSB	
0x0F	CAN termination 120Ω resistor	0	Not connected	default	
		1	Connected		

For complete information, contact us at info@texense.com

Ordering information

Ordering ref:

A-CAN-DG-V4-4B-Supply

5V

8.5V

12V

Direct

Ex: A-CAN-DG-V4-4B-8.5V